

Tooling Page

harbus® HM

Discrete tooling system for volume production	15.02
Tooling for backplanes	15.05
Insert blocks for male connectors	15.06
Repair tooling	15.07

harbus® HM Power

Tooling for angled male connectors	15.07
--	--------------

Mini Coax

Discrete tooling system for volume production	15.08
---	--------------

Press-in machines

Hand bench presses / pneumatic presses	15.09
CPM press-in machine ¹⁾	15.11

¹⁾ See separate catalogue

For economical and safe press-in of *harbus[®] HM* connectors with 5+2 and 8+2 rows, HARTING has developed a discrete tooling system.

Due to its modular structure it can be adapted to any connector configuration that needs to be pressed-in extremely quickly and securely.

Therefore a top and a bottom tool for each connector style is available. These tools are inserted in a top or bottom carrier tool with a groove, thus guaranteeing exact position of the top and bottom tools and the connectors.

To use identical carrier tools for all connector configurations, HARTING offer spacer blocks to fill gaps between adjacent top or bottom tools.

The carrier tool is either completely filled with top or bottom tools or respective spacer blocks, making it possible to press-in single modules.

To press-in female connectors with pre-installed upper shields, separate top and bottom tools are available.

For lower shield press-in the tooling can be changed easily.

For further information please check our operating instructions or contact your HARTING representative.

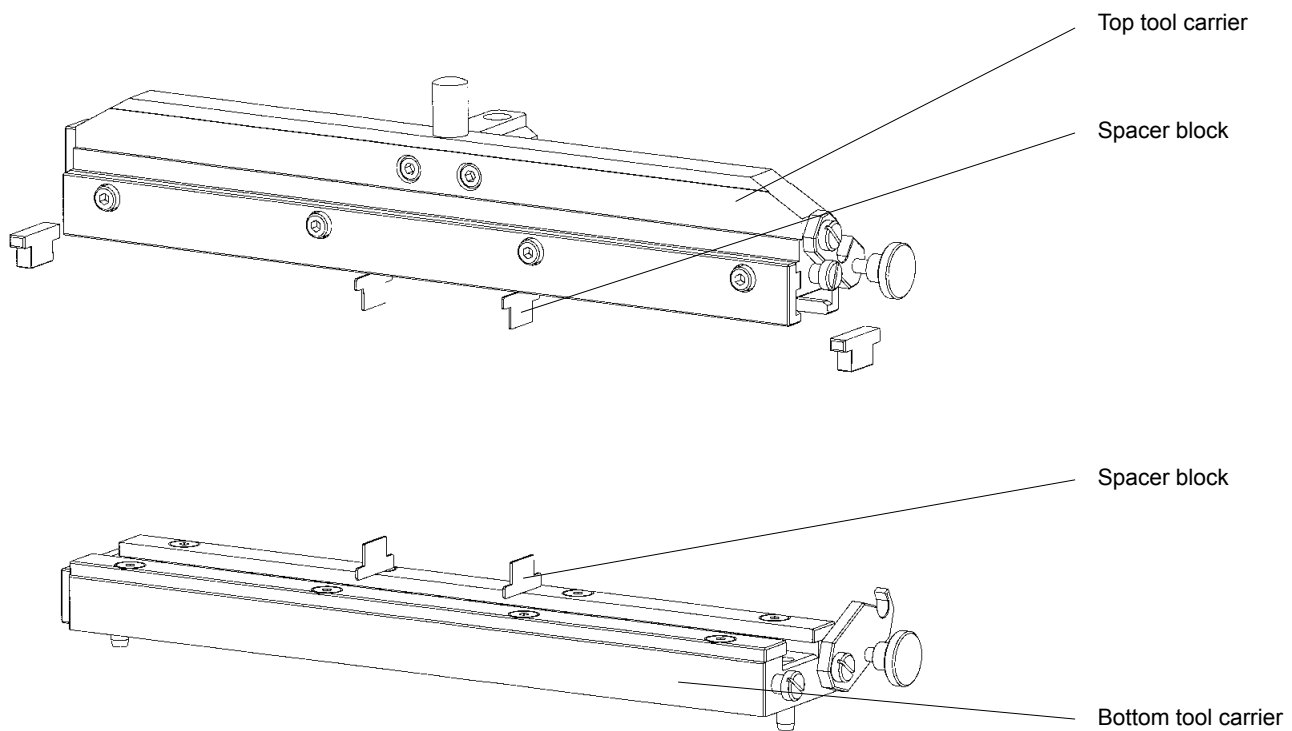

Fig. 1: Basis tools of the discrete tooling system

Basis tools for all connector types

Part number connector	Tool identification	Part number tool	Part number connector	Tool identification	Part number tool
17 xx xxx xxxx	Top tool carrier <i>harbus[®] HM</i>	17 99 000 0012	17 xx xxx xxxx	Spacer block 25 mm	17 99 000 0055
17 xx xxx xxxx	Bottom tool carrier <i>harbus[®] HM</i>	17 99 000 0013	17 xx xxx xxxx	Spacer block 38 mm	17 99 000 0054
17 xx xxx xxxx	Top tool carrier <i>harbus[®] HM 3U</i>	17 99 000 0073	17 xx xxx xxxx	Spacer block 44 mm	17 99 000 0053
17 xx xxx xxxx	Bottom tool carrier <i>harbus[®] HM 3U</i>	17 99 000 0074	17 xx xxx xxxx	Spacer block 50 mm	17 99 000 0052
17 xx xxx xxxx	Spacer block 0.67 mm (CompactPCI)	17 99 000 0057	17 xx xxx xxxx	Centering plate female left	17 99 000 0060
17 xx xxx xxxx	Spacer block 5 mm	17 99 000 0056	17 xx xxx xxxx	Centering plate female right	17 99 000 0061

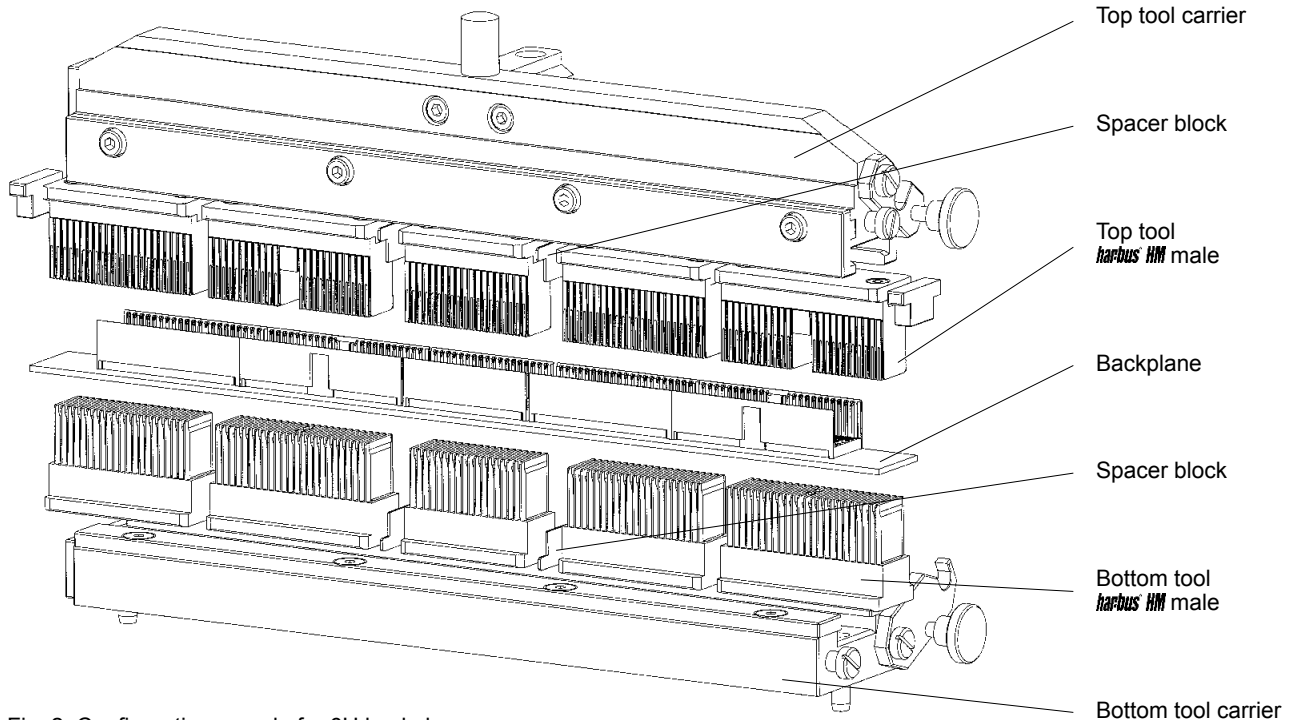

Fig. 2: Configuration sample for 6U backplane

Tools for straight male connectors

Part number connector	Tool identification	Part number tool	Part number connector	Tool identification	Part number tool
17 01 xxx xxxx	Top tool, male, type A	17 99 000 0014	17 11 xxx xxxx	Top tool, male, type D	17 99 000 0022
17 01 xxx xxxx	Bottom tool, male, type A	17 99 000 0026	17 11 xxx xxxx	Bottom tool, male, type D	17 99 000 0028
17 02 xxx xxxx	Top tool, male, type B	17 99 000 0020	17 12 xxx xxxx	Top tool, male, type E	17 99 000 0023
17 02 xxx xxxx	Bottom tool, male, type B	17 99 000 0026	17 12 xxx xxxx	Bottom tool, male, type E	17 99 000 0028
17 04 xxx xxxx	Top tool, male, type B	17 99 000 0019	17 13 xxx xxxx	Top tool, male, type AB	17 99 000 0015
17 04 xxx xxxx	Bottom tool, male, type B	17 99 000 0025	17 13 xxx xxxx	Bottom tool, male, type AB	17 99 000 0024
17 05 xxx xxxx	Top tool, male, type B	17 99 000 0018	17 14 xxx xxxx	Top tool, male, type AB	17 99 000 0016
17 05 xxx xxxx	Bottom tool, male, type B	17 99 000 0024	17 14 xxx xxxx	Bottom tool, male, type AB	17 99 000 0025
17 03 xxx xxxx	Top tool, male, type C	17 99 000 0021	17 15 xxx xxxx	Top tool, male, type AB	17 99 000 0017
17 03 xxx xxxx	Bottom tool, male, type C	17 99 000 0027	17 15 xxx xxxx	Bottom tool, male, type AB	17 99 000 0026

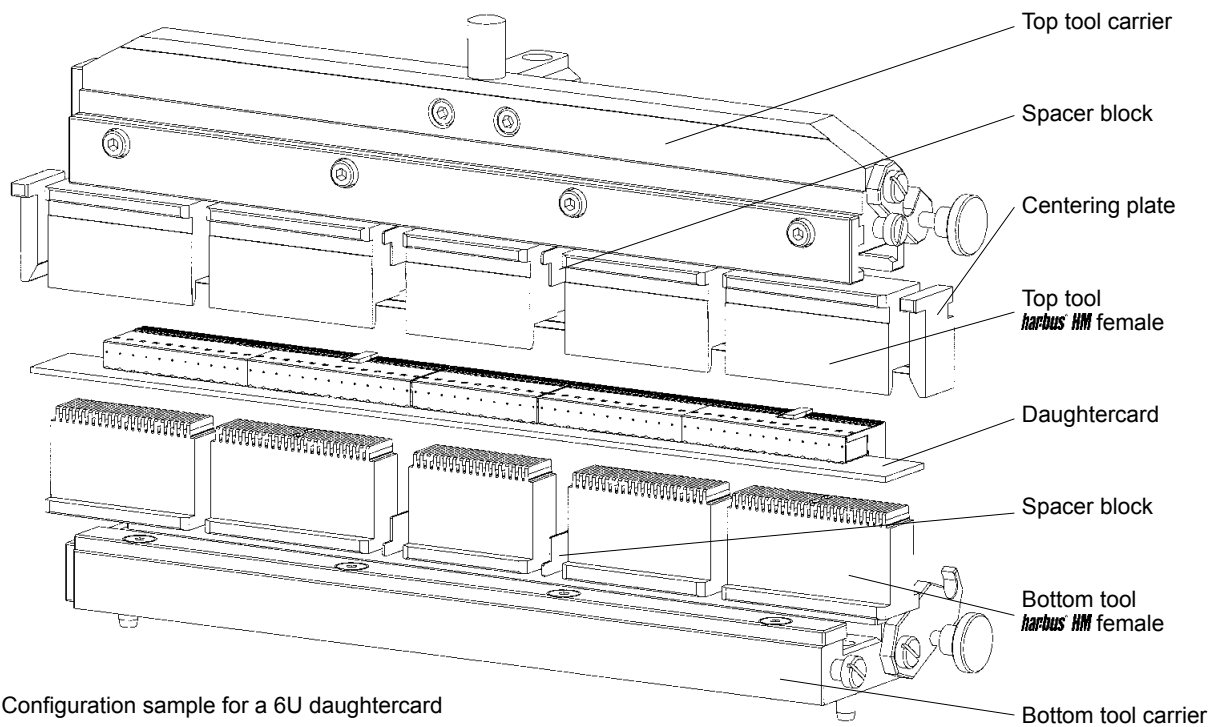

Fig. 3: Configuration sample for a 6U daughtercard

Tools for angled female connectors

Part number connector	Tool identification	Part number tool	Part number connector	Tool identification	Part number tool
17 21 xxx xxxx	Top tool, female, type A	17 99 000 0029	17 31 xxx xxxx	Top tool, female, type D	17 99 000 0042
17 21 xxx xxxx	Bottom tool, female, type A	17 99 000 0046	17 31 xxx xxxx	Bottom tool, female, type D	17 99 000 0048
17 22 xxx xxxx	Top tool, female, type B	17 99 000 0038	17 32 xxx xxxx	Top tool, female, type E	17 99 000 0042
17 22 xxx xxxx	Bottom tool, female, type B	17 99 000 0046	17 32 xxx xxxx	Bottom tool, female, type E	17 99 000 0048
17 24 xxx xxxx	Top tool, female, type B	17 99 000 0036	17 33 xxx xxxx	Top tool, female, type AB	17 99 000 0032
17 24 xxx xxxx	Bottom tool, female, type B	17 99 000 0045	17 33 xxx xxxx	Bottom tool, female, type AB	17 99 000 0044
17 25 xxx xxxx	Top tool, female, type B	17 99 000 0034	17 34 xxx xxxx	Top tool, female, type AB	17 99 000 0058
17 25 xxx xxxx	Bottom tool, female, type B	17 99 000 0044	17 34 xxx xxxx	Bottom tool, female, type AB	17 99 000 0045
17 23 xxx xxxx	Top tool, female, type C	17 99 000 0040	17 35 xxx xxxx	Top tool, female, type AB	17 99 000 0029
17 23 xxx xxxx	Bottom tool, female, type C	17 99 000 0047	17 35 xxx xxxx	Bottom tool, female, type AB	17 99 000 0046

Tools for angled shielded female connectors

Part number connector	Tool identification	Part number tool	Part number connector	Tool identification	Part number tool
17 21 xxx xxxx	Top tool, female, type A upper shield	17 99 000 0030	17 34 xxx xxxx	Top tool, female, type AB upper shield	17 99 000 0059
17 21 xxx xxxx	Top tool, female, type A divided shield computer telephony	17 99 000 0031	17 35 xxx xxxx	Top tool, female, type AB upper shield	17 99 000 0030
17 22 xxx xxxx	Top tool, female, type B upper shield	17 99 000 0039	17 21 xxx xxxx	Press-in die lower shield type A	17 99 000 0051
17 24 xxx xxxx	Top tool, female, type B upper shield	17 99 000 0037	17 22 xxx xxxx	Press-in die lower shield type B	17 99 000 0051
17 25 xxx xxxx	Top tool, female, type B upper shield	17 99 000 0035	17 24 xxx xxxx	Press-in die lower shield type B	17 99 000 0050
17 23 xxx xxxx	Top tool, female, type C upper shield	17 99 000 0041	17 25 xxx xxxx	Press-in die lower shield type B	17 99 000 0049
17 31 xxx xxxx	Top tool, female, type D upper shield	17 99 000 0043	17 31 xxx xxxx	Press-in die lower shield type D	17 99 000 0051
17 32 xxx xxxx	Top tool, female, type E upper shield	17 99 000 0043	17 32 xxx xxxx	Press-in die lower shield type E	17 99 000 0051
17 33 xxx xxxx	Top tool, female, type AB upper shield	17 99 000 0033	17 33 xxx xxxx	Press-in die lower shield type AB	17 99 000 0049
			17 34 xxx xxxx	Press-in die lower shield type AB	17 99 000 0050
			17 35 xxx xxxx	Press-in die lower shield type AB	17 99 000 0051

For 6U backplanes with CompactPCI configuration, HARTING has developed this start-up tooling.

The tooth inserts are interchangeable, so that the tooling can be used for other connector configurations as well as for CompactPCI.

The basis is a top tool carrier with tooth inserts, that are engaged alternately.

The bottom tool should preferably be a loadnest, which carries and aligns the pcb.

Therefore this tooling assembly can be used without any additional set-up time.

For detailed information please contact your local HARTING representative.

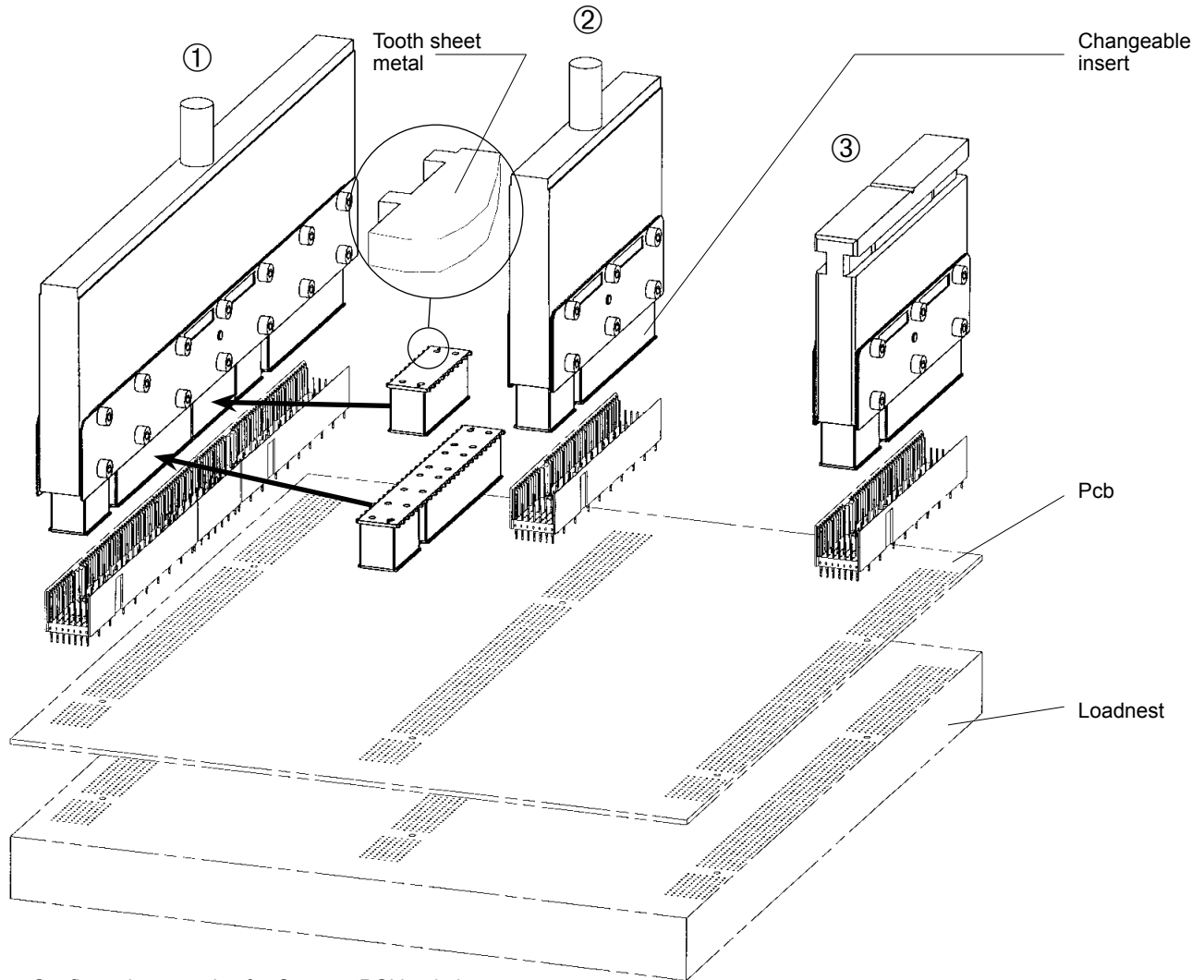

Fig. 4: Configuration samples for CompactPCI backplanes

Tools for straight male connectors

Tool identification	Part number tool	Tool identification	Part number tool
① Insert top tool for 6U CompactPCI	17 99 000 0063	Tooth insert for type Monoblock 47	17 99 000 0066
② Insert top tool for 3U CompactPCI	17 99 000 0065		
③ Insert top tool for rotatable tool changer	on request	Tooth insert for type B 19 positions	17 99 000 0068

The insert blocks can be used to press-in **harbus[®] HM** male connectors without any special top tool. These blocks will be put into the connectors manually or automatically (using insertion removal station, see page 15.13).

To press-in the connector no precise position is needed and can be done by a simple flat rock die. This will accelerate the cycle time of the press-in process dramatically.

Insert blocks are developed for use with a loadnest.

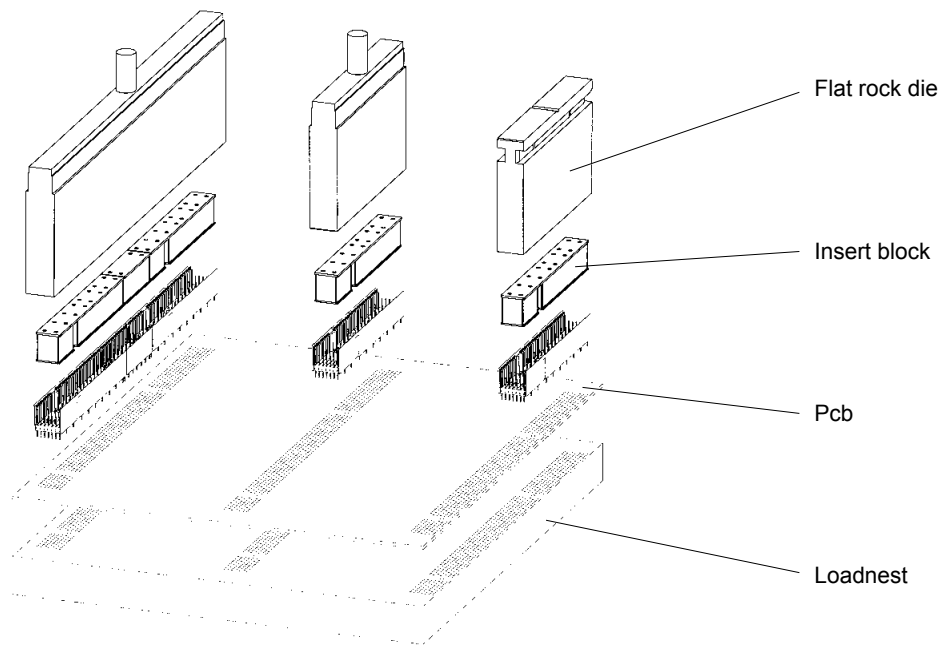

Fig. 5: Application samples for insert blocks

Insert blocks for straight male connectors

Part number connector	Tool identification	Quantity and part number tool
17 01 xxx xxxx	Insert block for type A	1 x 17 99 000 0009 or (2 x 17 99 000 0001)
17 04 xxx xxxx	Insert block for type B	1 x 17 99 000 0004
17 05 xxx xxxx	Insert block for type B	1 x 17 99 000 0002
17 02 xxx xxxx	Insert block for type B	1 x 17 99 000 0003
17 03 xxx xxxx	Insert block for type C	1 x 17 99 000 0001
17 06 xxx xxxx	Insert block for type Monoblock 47	1 x 17 99 000 0008 or (1 x 17 99 000 0001 and 1 x 17 99 000 0005)
17 11 xxx xxxx	Insert block for type D	2 x 17 99 000 0006
17 12 xxx xxxx	Insert block for type E	1 x 17 99 000 0007
17 13 xxx xxxx	Insert block for type AB	1 x 17 99 000 0069
17 14 xxx xxxx	Insert block for type AB	1 x 17 99 000 0070
17 15 xxx xxxx	Insert block for type AB	1 x 17 99 000 0071
17 10 xxx xxxx	Insert block for type DE	1 x 17 99 000 0072
17 4x xxx xxxx	Insert block for type 6-row with 72 contacts	1 x 17 99 000 0090
17 4x xxx xxxx	Insert block for type 6-row with 144 contacts	1 x 17 99 000 0091

Flat rock dies

Part number connector	Tool identification	Part number tool
17 xx xxx xxxx	Flat rock die for 6U	07 79 000 0155
17 xx xxx xxxx	Flat rock die for 3U	07 79 000 0156

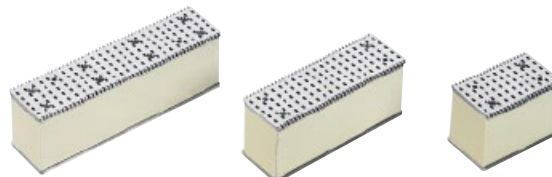

The insert block 17 99 000 0001 e.g. can be used for the types A, C and Monoblock 47.

Identification	for use with	Part number	Drawing	Dimensions [mm]
Tool kit shroud removal	harbus[®] HM	17 99 000 0095		
Insertion and repair tool for single contact	harbus[®] HM	17 99 000 0094		
Removal tool for single male contacts	harbus[®] HM	09 99 000 0239		
Mounting tool for coding key	harbus[®] HM	17 99 000 0093		

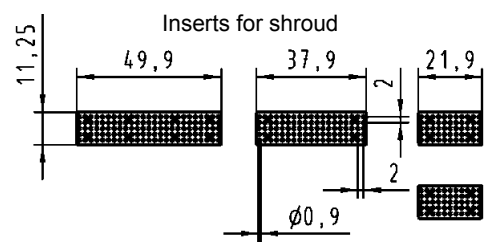

Identification	for use with	Part number	Drawing	Dimensions [mm]
Top tool for angled male connectors	harbus[®] HM Power	17 99 000 0102		
Bottom tool for angled male connectors	harbus[®] HM Power	17 99 000 0103		

Straight Mini Coax connectors can be pressed-in with a flat die and a top tool delivered with the connectors. This top tool can be used as contact protection and remains in the connector until the daughtercard is mated.

Angled Mini Coax connectors will be pressed-in with separate top and bottom tools, which will be mounted into a common body.

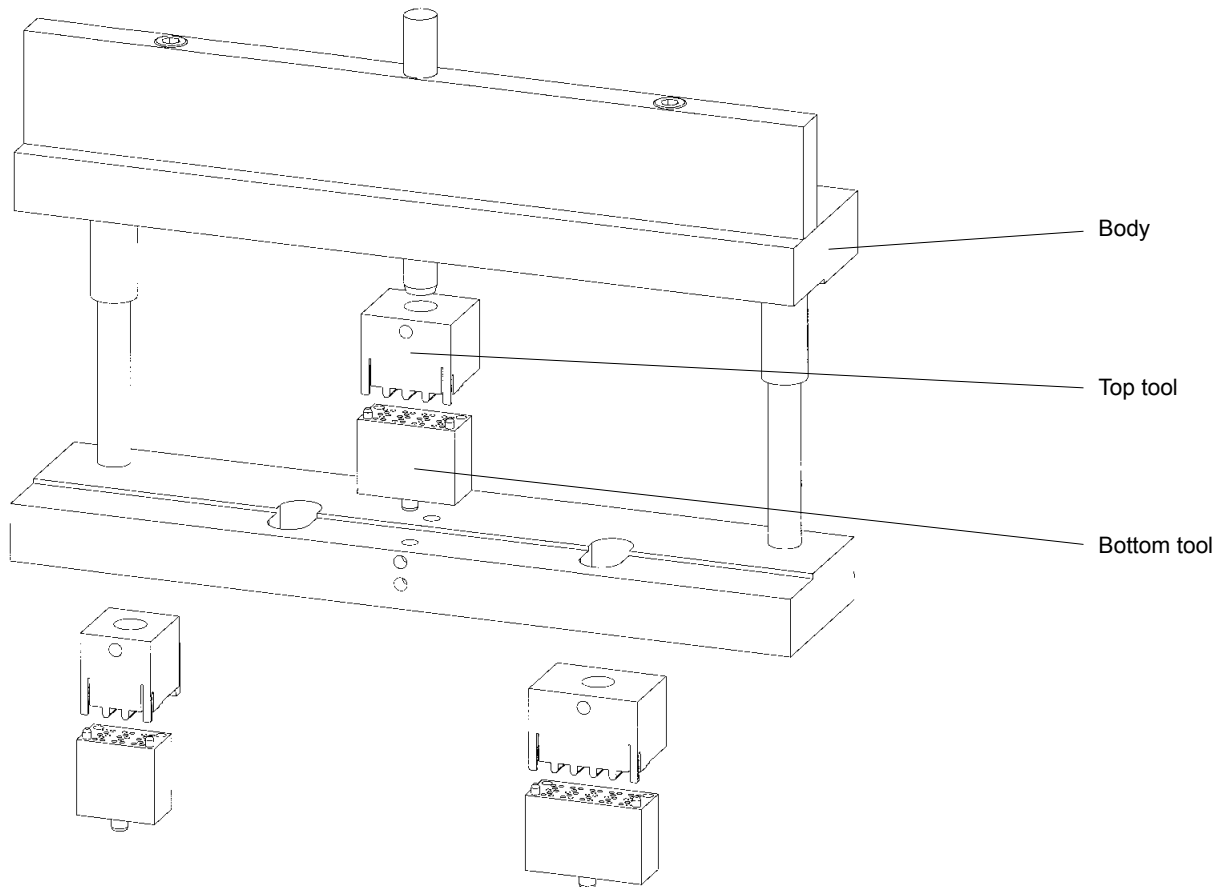

Fig. 6: Configuration for angled modules

Tools for straight modules

Part number connector	Tool identification	Part number tool
07 11 xxx xxxx	1 SU Mini Coax Standard bottom tool	on request
07 11 xxx xxxx	1.25 SU Mini Coax Standard bottom tool	on request
07 11 xxx xxxx	1.50 SU Mini Coax Standard bottom tool	on request

Tools for angled modules

Part number connector	Tool identification	Part number tool
07 31 xxx xxxx	Body	07 79 000 0061
07 31 xxx xxxx	1 SU Mini Coax Standard bottom tool	07 79 000 0045
07 31 xxx xxxx	1 SU Mini Coax Standard top tool	07 79 000 0080
07 31 xxx xxxx	1.25 SU Mini Coax Standard bottom tool	07 79 000 0034
07 31 xxx xxxx	1.25 SU Mini Coax Standard top tool	07 79 000 0081
07 31 xxx xxxx	1.50 SU Mini Coax Standard bottom tool	07 79 000 0171
07 31 xxx xxxx	1.50 SU Mini Coax Standard top tool	07 79 000 0170
07 31 xxx xxxx	1 SU Mini Coax single-row bottom tool	07 79 000 0205
07 31 xxx xxxx	1 SU Mini Coax single-row top tool	07 79 000 0204

Identification	Part number	Drawing	Dimensions in mm
Hand bench press	09 99 000 0201		<p>Technical characteristics</p> <p>Working stroke 25 mm</p> <p>Press force 15 kN max.</p> <p>Hole \varnothing in the ram \varnothing 10 mm</p> <p>Net weight approx. 23 kg</p>
Pneumatic press 40 kN	09 99 000 0282		<p>Technical characteristics</p> <p>Total stroke 48 mm</p> <p>Working stroke 0-6 mm</p> <p>Press force 40 kN max.</p> <p>Air pressure 6 bar</p> <p>Hole \varnothing in the ram \varnothing 10.01 mm</p> <p>Net weight 136 kg</p> <p>Power supply 110 V / 220 V AC</p>
Adaptor for height compensation ¹⁾	09 99 000 0279		
Guide frame with base plate Standard type for pcb size x = 123,5 - 309,5 mm	09 99 000 0244		
Long type ²⁾ for pcb size x = 123,5 - 668,5 mm	09 99 000 0261		
Base plate	09 99 000 0255		

¹⁾ suitable for 09 99 000 0282 and all CPM machines (see page 15.11 pp.)

²⁾ not suitable for hand bench press

The CPM *prestige* press-in machine with a graphical user interface

The **CPM *prestige*** is a consequential development of the successful CPM 2001 press-in machines. The excellent design, supported by a wide range of tools presents a convenient, easy and comfortable way of processing backplanes and daughtercards. The machine is fully programmable and is supplied with a graphical user interface for control and visualisation of the complete process. The use of a microprocessor control allows the recognition and storage of different component heights, so that the pressing-in of different components is initiated simultaneously with only one button. The user-friendly touch-screen guides the user through the menu-orientated process controls.

The visualisation of the entire press-in process (the position of the connector, press-in forces etc.) allows the rapid recognition and eradication of the possible error sources. With the addition of a barcode reader (1D and 2D)¹⁾ the parameters of every pcb layout can be stored, recalled and loaded into the automated press-in programme. The extensive operation monitor functions simplify the service and support of the machine.

The machine employs the automatic switch-off system “autosense”, known worldwide for its reliability. The different connector types and the tolerances of the pcb are automatically recognised and taken into consideration at the press-in operation, thus maximising the process security.



Visual guiding system via touch monitor

Real photos of connectors and tools

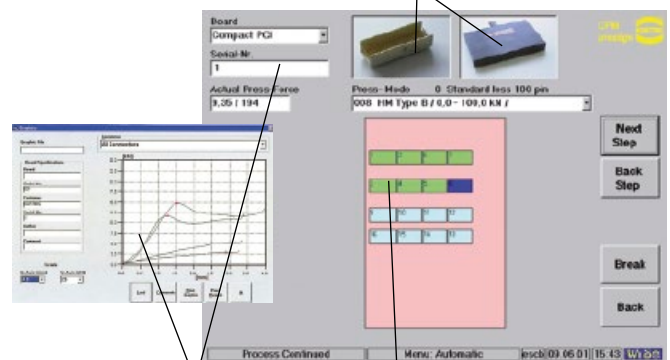

Process data

Layout with current position highlighted

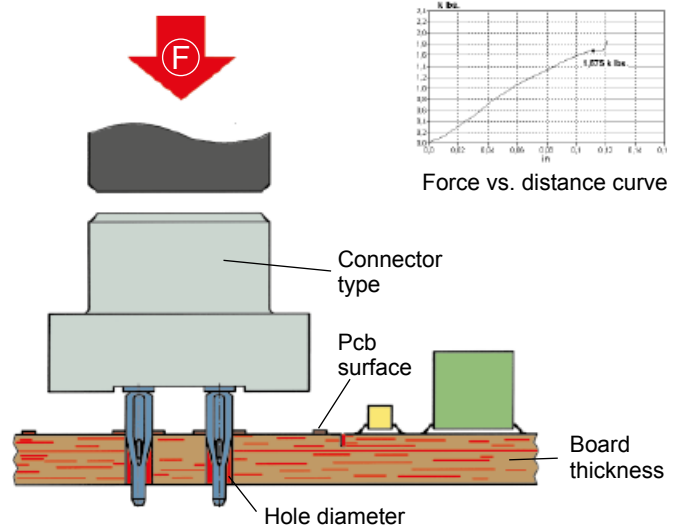

Shown are the four most considerable influences of the press-in process.

¹⁾ optional

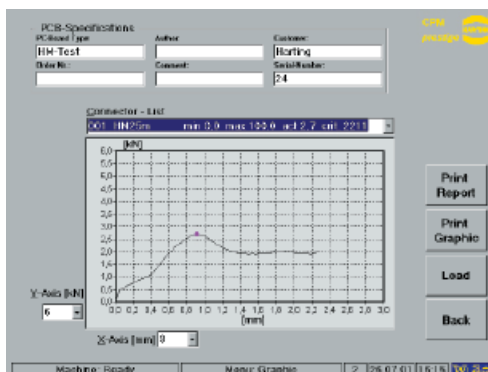

Quality control of press-in termination

The press-in force correlates with the diameter of the plated through hole and with the friction coefficient of the surface; therefore it can be used for a continuous monitoring of the process.

The retention force, as an indirect measure of the normal force, serves to qualify the process or random tests.



Part number 09 89 040 0000

Technical characteristics

Drive	electro-mechanical, servo
Press-in force	100 kN
max. pcb dimensions	600 x 1000 mm
Floor space	1200 x 1150 mm
Weight	980 kg
Power supply	208 / 380 / 400 / 415 V
Consumption	< 1 kW
Colour	on request

Fig. 7: **CPM prestige**
(incl. PC, control software, barcode reader, keyboard, touch screen)

Built-in features:

- Guiding rails (carbon/spring-loaded) for the secure positioning of the pcb
- Touch-screen and Industrial PC with UPS (uninterruptable power supply)
- Barcode reader for management ease of press-in programs
- All dimensions allow an easy integration into production lines

Process monitoring and quality assurance:

- Touch screen interface with graphical and verbal menus for all machine functions
- Autosense: automated press-in interruption at incorrect press-in forces
- Storage and validation of all press-in parameters via quality assurance software (press-in force tolerances)
- Continuous high-precision measurement and recording of press-in forces and distances
- Remote determination of errors and maintenance
- High flexibility through a modular tool range

Options:

- Rotatable tool changer
- Insertion removal station

Insertion removal station



Power supply 220 V / 50 Hz
Air pressure 6 bar (15-16 l/min.)

Part number **on request**
for pcb dimensions of max.
710 mm x 540 mm

Fig. 8: Bestseller **CPM prestige** with insertion removal station, adaptable to all HARTING press-in machines.

Principle:

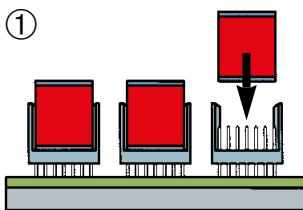

① Load all headers with inserts for **one press-in cycle**

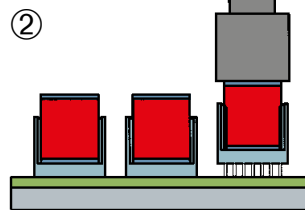

② Press-in all connectors with a flat die

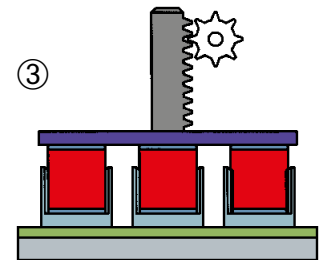

③ Position the magnetic plate

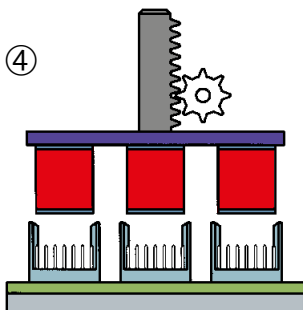

④ Remove all press-in inserts in one operation

Remove the processed pcb from the machine



⑤



⑥

Move the next pre-assembled pcb to the insert station

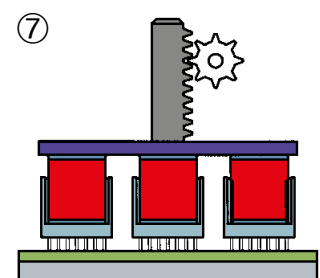

⑦ Load all headers in one operation

The insertion removal station has been developed both for the **CPM prestige** and the CPM 2001/s. It can additionally be used as stand alone equipment.

Today nearly all female connectors are designed for flat rock tooling. For every type of male connector specific tooling and a high degree of X-Y-process accuracy is required. Therefore HARTING offers press-in insert blocks that transfer all well known assembling advantages from female connectors to male headers.

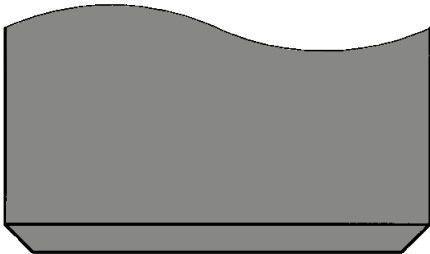

Advantages of press inserts

Robust tooling

No lateral force to pcb hole

No abrasion of the contact mating surface by the press tool

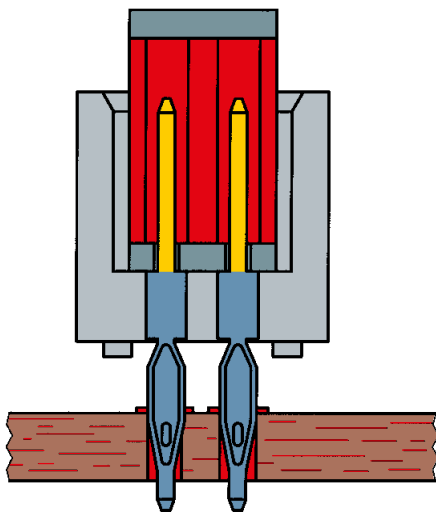

HARTING has already developed press-in inserts for all major male connector families on 2.54 mm, 2.5 mm and 2 mm pitches.

Inserts for any other special components can be developed on request.

The additional process for inserting and removing the press-in inserts can be efficiently done with the insertion removal station. This station removes all press-in inserts with a magnetic plate in one operation and inserts them into the next pre-assembled pcb with the necessary precision. (Principle see page 15.13).

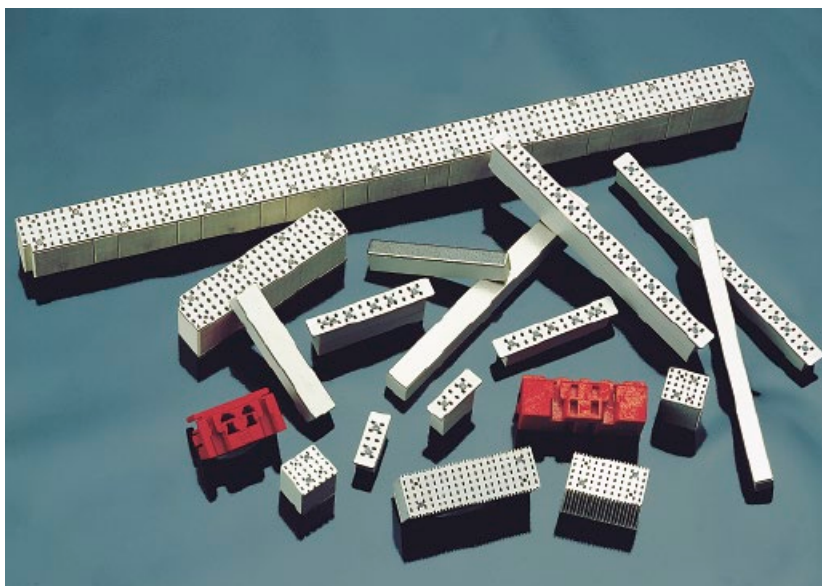

The cycle time for loading all headers is between 4 and 6 seconds, independent from the amount of press-in inserts.

To load the inserts automatically means also that connectors assembled in a wrong way will be recognised and errors consequently prevented.