

Today nearly all female connectors are designed for flat rock tooling. For every type of male connector specific tooling and a high degree of X-Y-process accuracy is required. Therefore HARTING offers press-in insert blocks that transfer all well known assembling advantages from female connectors to male headers.

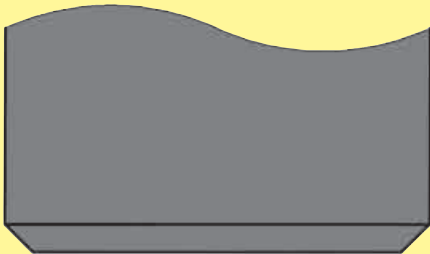

Advantages of press inserts

Robust tooling

No lateral force to pcb hole

No abrasion of the contact mating surface by the press tool

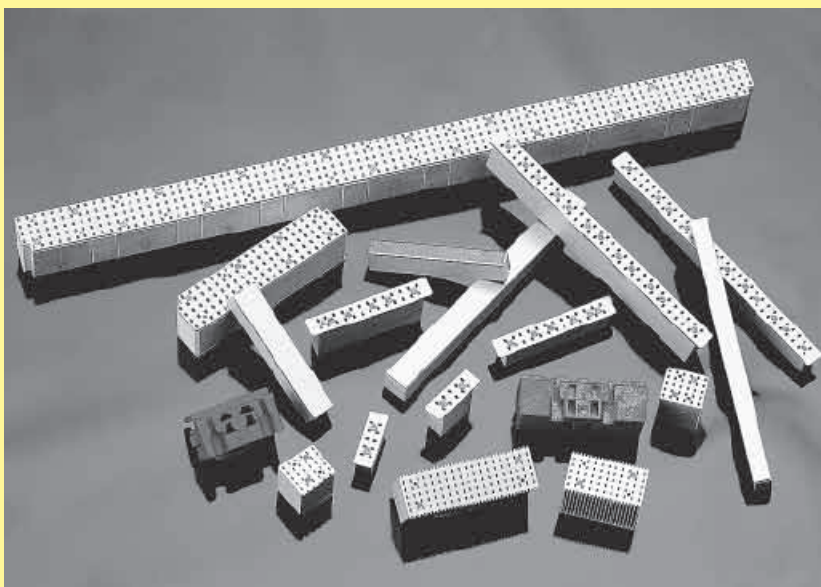
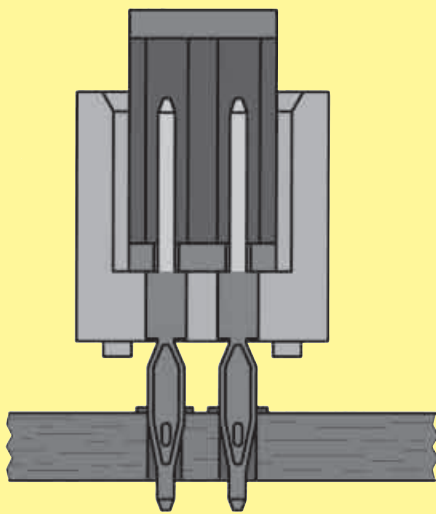

HARTING has already developed press-in inserts for all major male connector families on 2.54 mm, 2.5 mm and 2 mm pitches.

Inserts for any other special components can be developed on request.

The additional process for inserting and removing the press-in inserts can be efficiently done with the insertion removal station. This station removes all press-in inserts with a magnetic plate in one operation and inserts them into the next pre-assembled pcb with the necessary precision. (Principle see page 15.15).

The cycle time for loading all headers is between 4 and 6 seconds, independent from the amount of press-in inserts.

To load the inserts automatically means also that connectors assembled in a wrong way will be recognised and errors consequently prevented.