

Identification

Drawing

Dimensions in mm

Standard Versions

Mounting height 7.3 mm
 9-37 way
 for front panel
 4 units of width (TE)

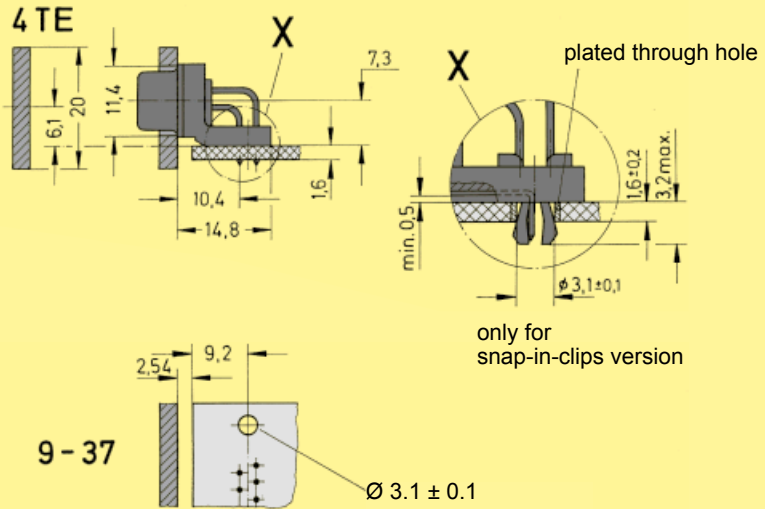

for connectors see pages 22.14 – 22.15

Low-Profile Versions

Mounting height 3.6 mm
 9-37 way
 for front panel
 3 units of width (TE)

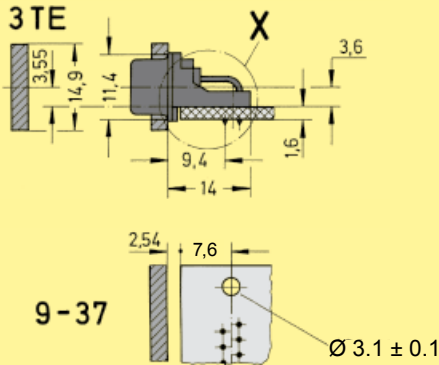

for connectors see pages 22.16 – 22.17

Panel cut out for front/rear mount

Values are taken from the CECC 75 301-802

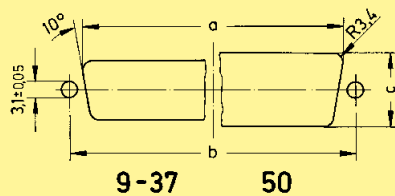

Front mount

Rear mount

	a ± 0.2	b ± 0.13	c ± 0.2
9	22.2	25.0	12.3
15	30.5	33.3	12.3
25	44.3	47.0	12.3
37	60.7	63.5	12.3
50	58.3	61.1	15.1

	a ± 0.2	b ± 0.13	c ± 0.2
9	20.5	25.0	11.4
15	28.8	33.3	11.4
25	42.5	47.0	11.4
37	59.1	63.5	11.4
50	56.3	61.1	14.1