

Tooling compatible for complete interface connectors range

Modular tooling system  
for starting connector press-in

The diversity of connector types with press-in terminations and varying termination styles make it necessary to have a simple, flexible tooling system that can be continuously updated.

The HARTING modular tooling system has significant advantages in terms of economic assembly of the many connector types with press-in terminations. The basic modules of the tooling system which will always be required are:

- Press
- Top tool
- Bottom tool
- Base plate

To increase automation and productivity the following modules may be added to the basic assembly:

- Guide frame with base plate for accurate positioning of the pcb up to a length of 600 mm
- Guide frame "Standard" for hand bench press and pneumatic press and pcb height of 123.5 up to 309.5 mm
- Guide frame "Long" for pneumatic press and pcb height of 123.5 up to 668.5 mm

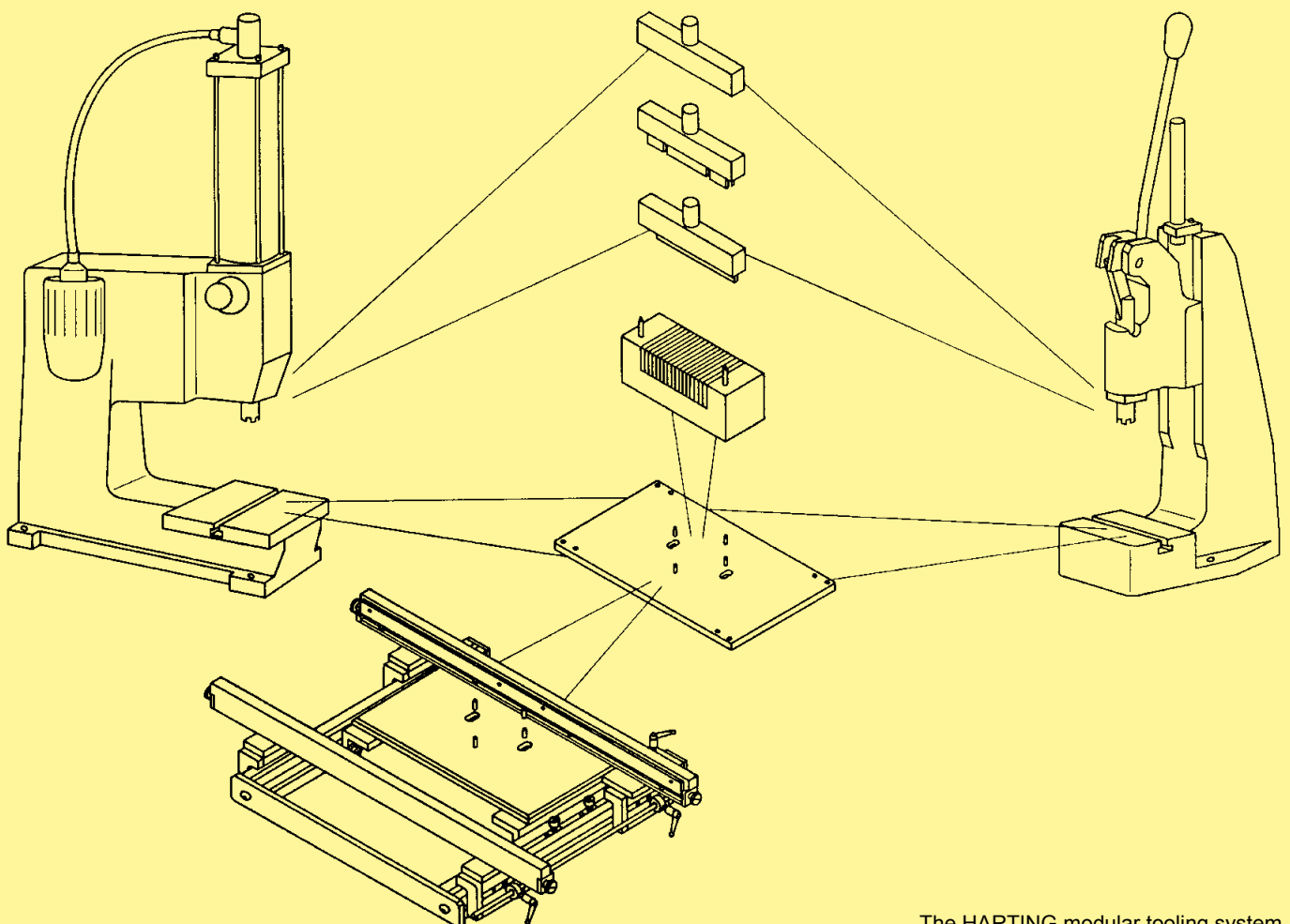

Tooling  
press-in