

Tooling compatible for complete interface connectors range

Handling indications

When setting up an assembly machine it is not necessary to set the working height of the press and adjust the base plate more than once. There is no need for further adjustments. All the other adaptations for various applications are performed efficiently and are reliant by various combinations of individual modules.

Positioning the bottom tool in relation to the top tool

The ram of the HARTING press is generally provided with a cross-shaped groove which accurately positions the top tool in steps of 90°.

Two guide pins position the bottom tool in relation to the top tool simply and accurately.

These guide pins cannot be used for positioning the pcb or the connector!

Two pairs of pins on the base plate locate the bottom tool in relation to the top tool in steps of 90°.

Bottom tool (narrow version)

In addition to the square bottom tool with multi-functional properties, HARTING offers the alternative of a narrow bottom tool for assembling connectors with straight press-in terminations. This tool supports the pcb within the press-in connector zone and therefore makes it possible to assemble connectors where electronic components are to be placed in close proximity.

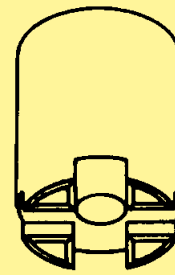

Ram with cross-shaped groove

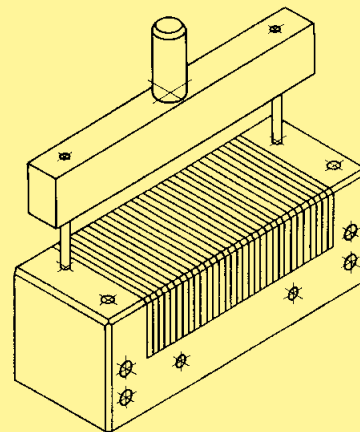

Positioning the bottom tool in relation to top tool

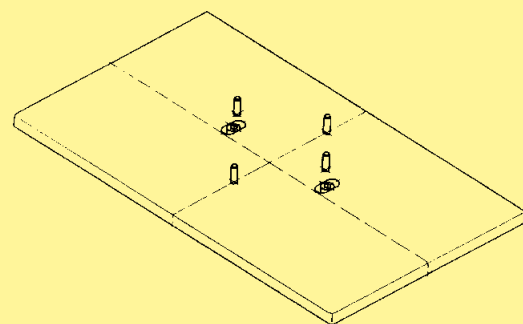

Base plate with pairs of location pins at 90°

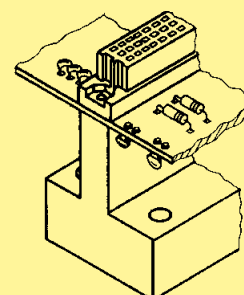

Narrow version of the bottom tool for special applications